

An architectural rendering of a modern residential complex. The buildings feature a prominent light-colored wood facade and large glass windows. Balconies with metal railings and potted plants are visible on multiple levels. A central courtyard with a stone-paved path, greenery, and people is shown. The scene is set during the golden hour, with warm lighting and a clear sky. The text 'Lavemissionsbyggeri' is overlaid in the bottom left, and the 'EFFEKT' logo is in the bottom right.

# Lavemissionsbyggeri

**EFFEKT**

**Kasper Ellegaard**  
**Impact Lead @EFFEKT**

**01.**

**Strategisk kontekst**

Svigt og spild i byggeriet

Designproces

Lavemissionsbyggeri som konkurrencefordel

**02.**

**En metode til lavemissionsbyggeri**

Case

- Living Places

- Home Earth

- Guimarães

**03.**

**Heuristikker**

# 01. Strategisk kontekst

Svigt og spild i byggeriet

Designproces

Lavemissionsbyggeri som konkurrencefordel

## Spild i Byggeriet (Hansen, 2024)

Omfanget af svigt skønnet til **10 % af produktionsværdien i byggebranchen, svarende til 12 mia. kr.**

På opfordring fra økonomi- og erhvervsminister Bendt Bendtsen har byggeriets parter i 2005 lavet en handlingsplan, der skal halvere antallet af fejl og mangler i branchen, inden udgangen af 2008.



**HVAD FORSTÅR VI VED BYGGESKADER – OG  
HVAD KOSTER DE OS?**

ERNST JAN DE PLACE HANSEN  
SEKTIONSLEDER, SENIORFORSKER  
BUILD, AALBORG UNIVERSITET

Byggeskadedagen 2024  
IDA BYG og IDA Bygningsfysik  
19. nov. 2024  
deplace@build.aau.dk

# Tre års kamp mod byggesjusk fejler

Konstruktionsfejl · 6. februar 2009 kl. 08:09 · 12 kommentarer

**Byggebranchen og Erhvervs- og Byggestyrelsen lovede i 2005 at halvere antallet af byggefejl på tre år. Men antallet af fejl er uændret, viser ny evaluering.**



**Ulrik Andersen**

Redaktør, BuildingTech

Følg

Artiklen er ældre end 30 dage

»Vi vil halvere antallet af byggefejl på tre år«. Det lovede daværende økonomi- og erhvervsminister Bendt Bendtsen (K) og byggebranchens topfolk i 2005. Men i dag bliver der fundet lige så mange utætte tage og skæve gulve som for tre år siden.

# Linear collaboration

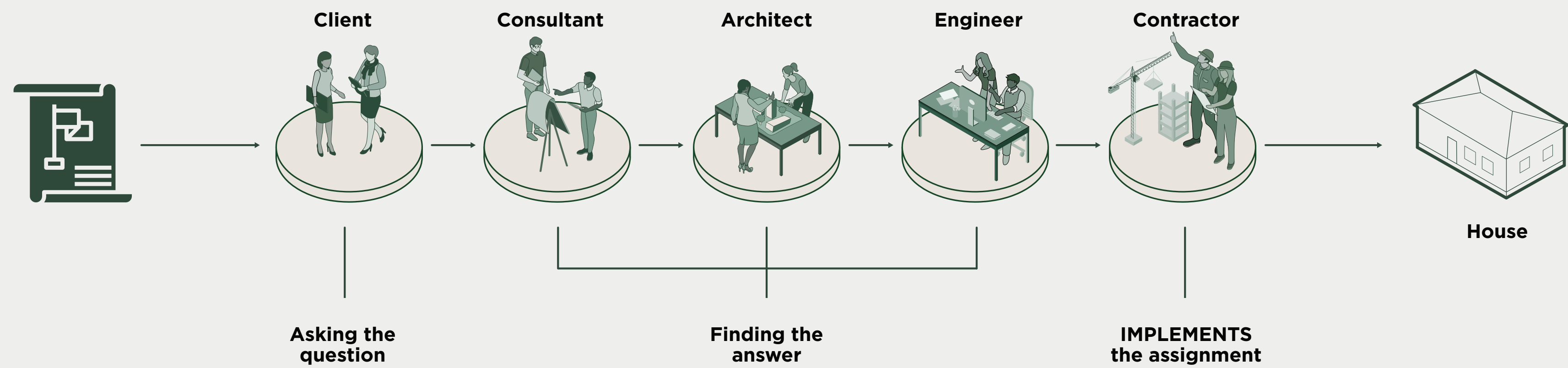

# Linear collaboration

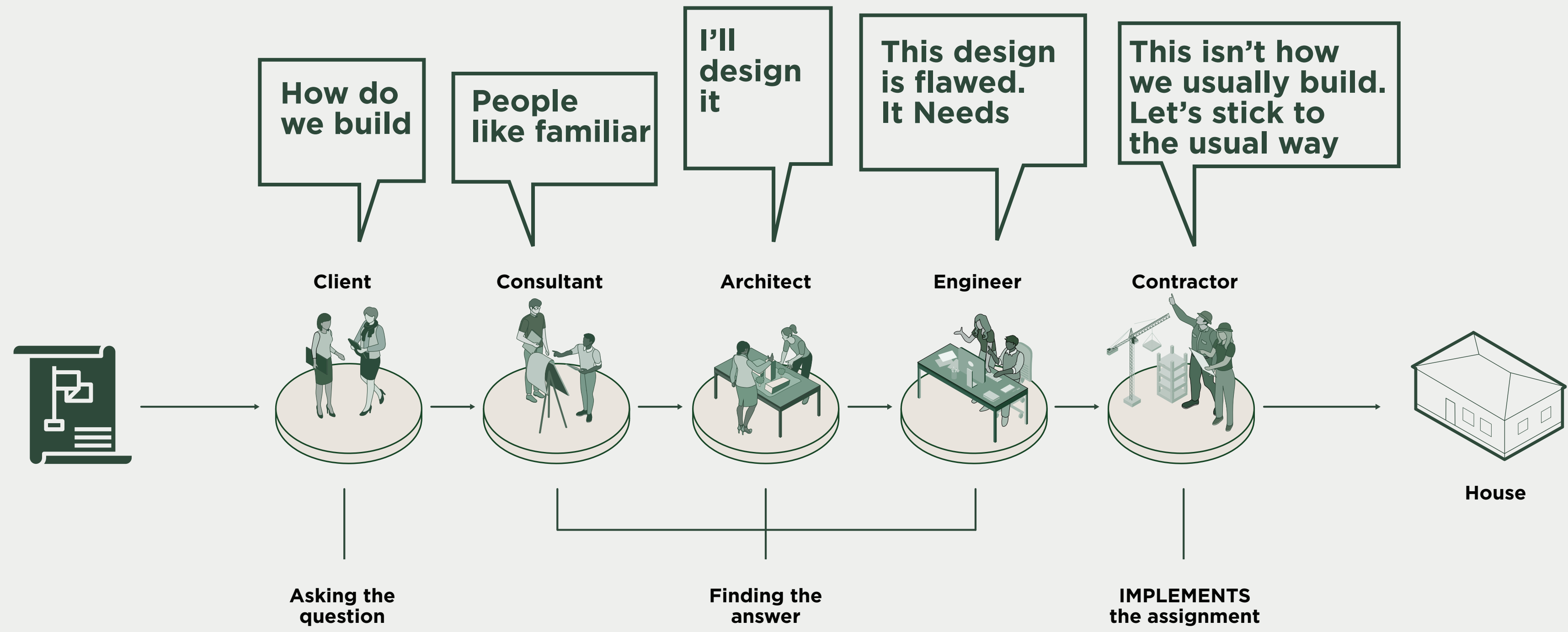

# Transformative partnership

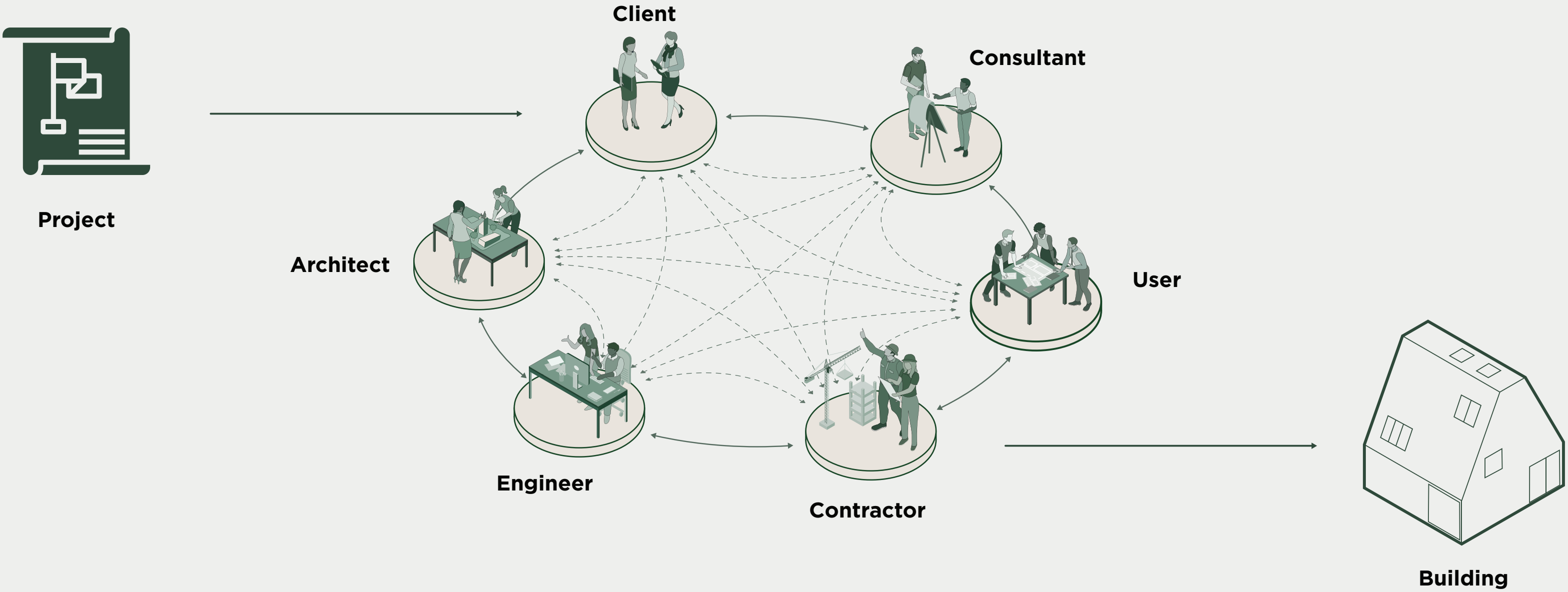

**Transformative partnerships**

- 1. Asking the right questions
- 2. Finding the right answers
- 3. Completes assignment

# Transformative partnership

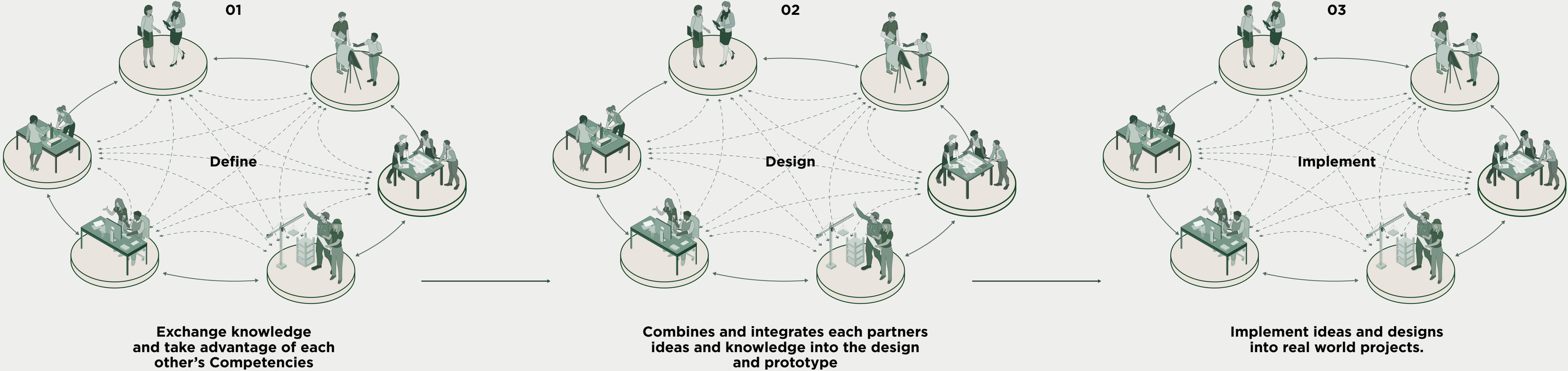

---

# Design process

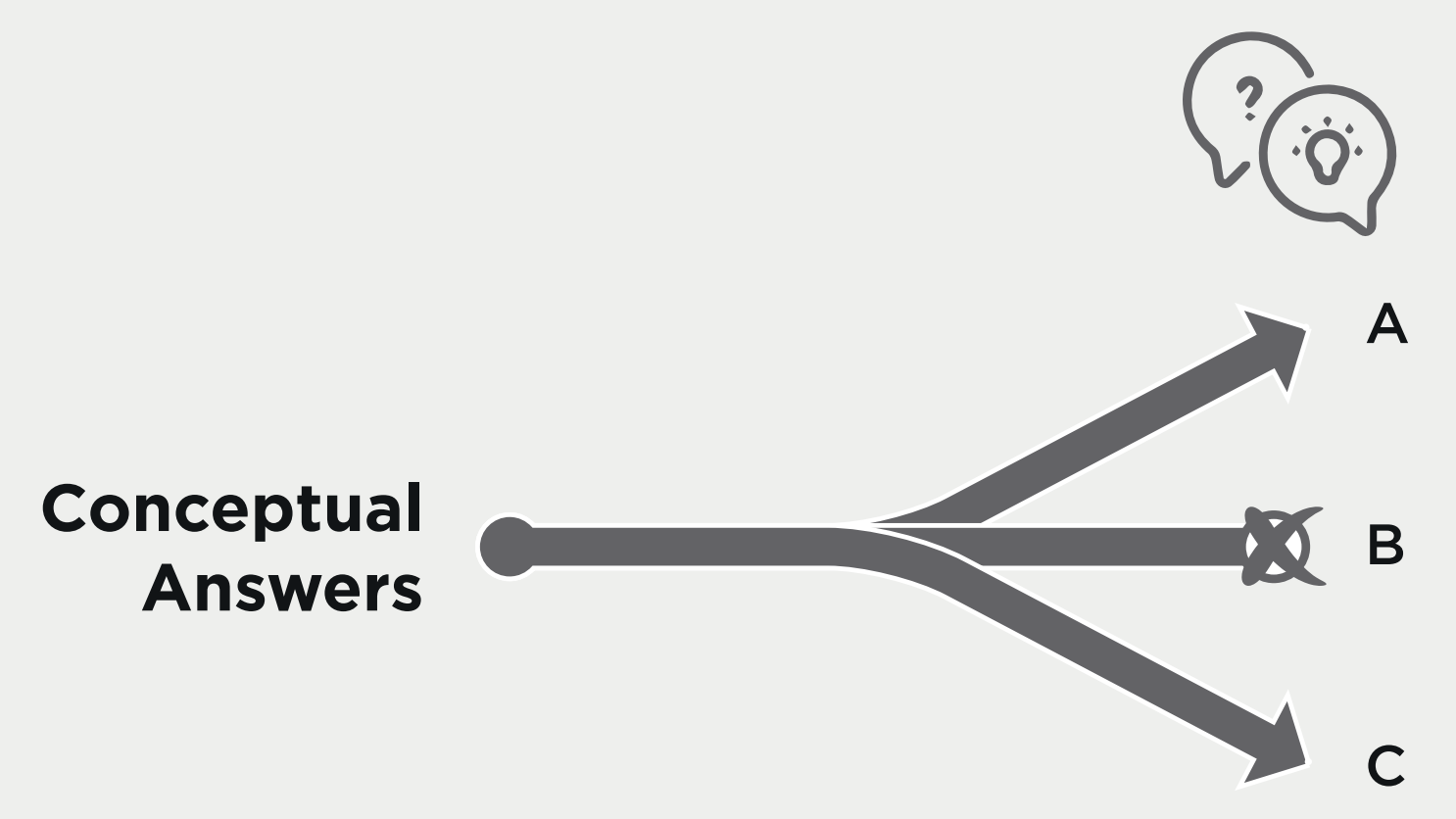

---

# Design process

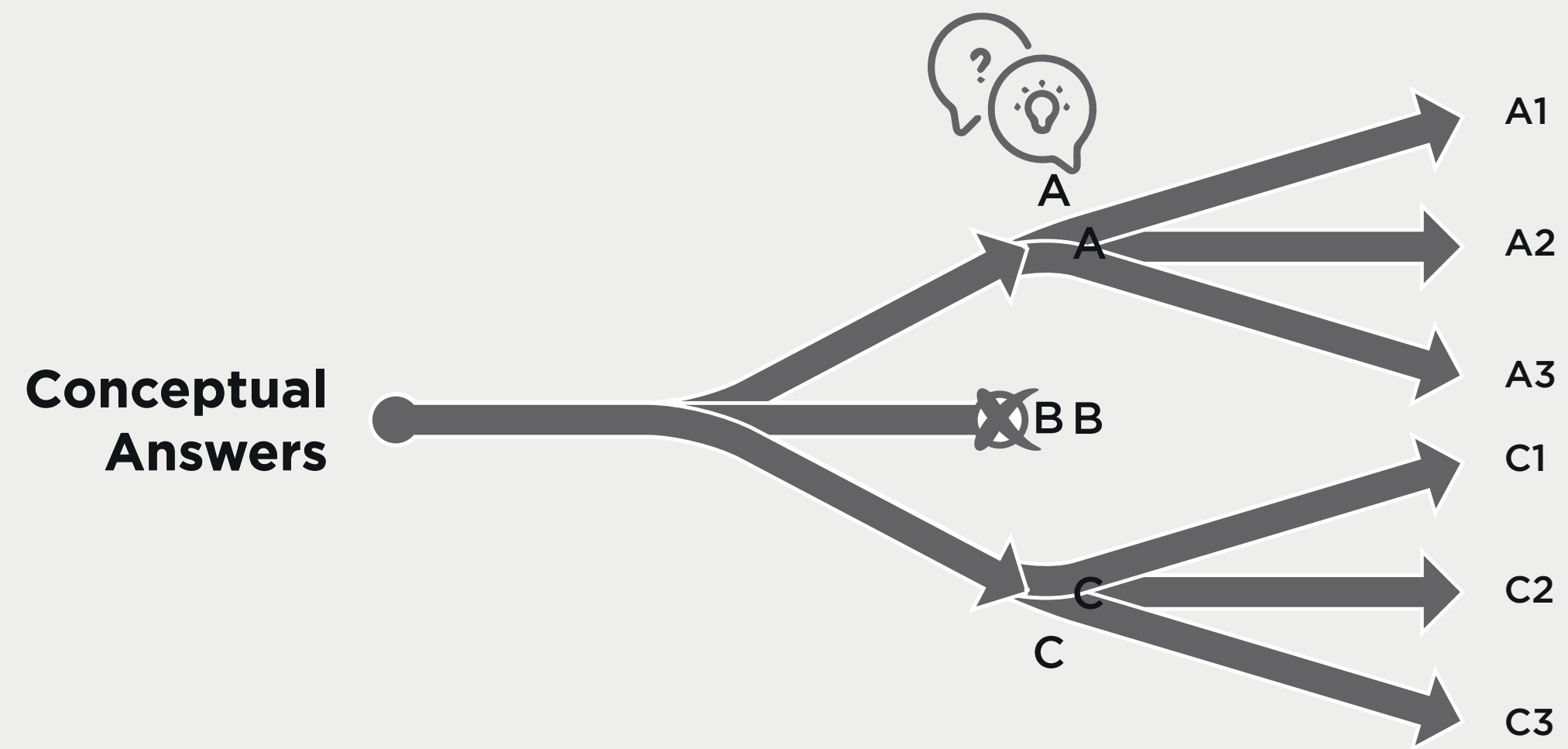

---

# Design process

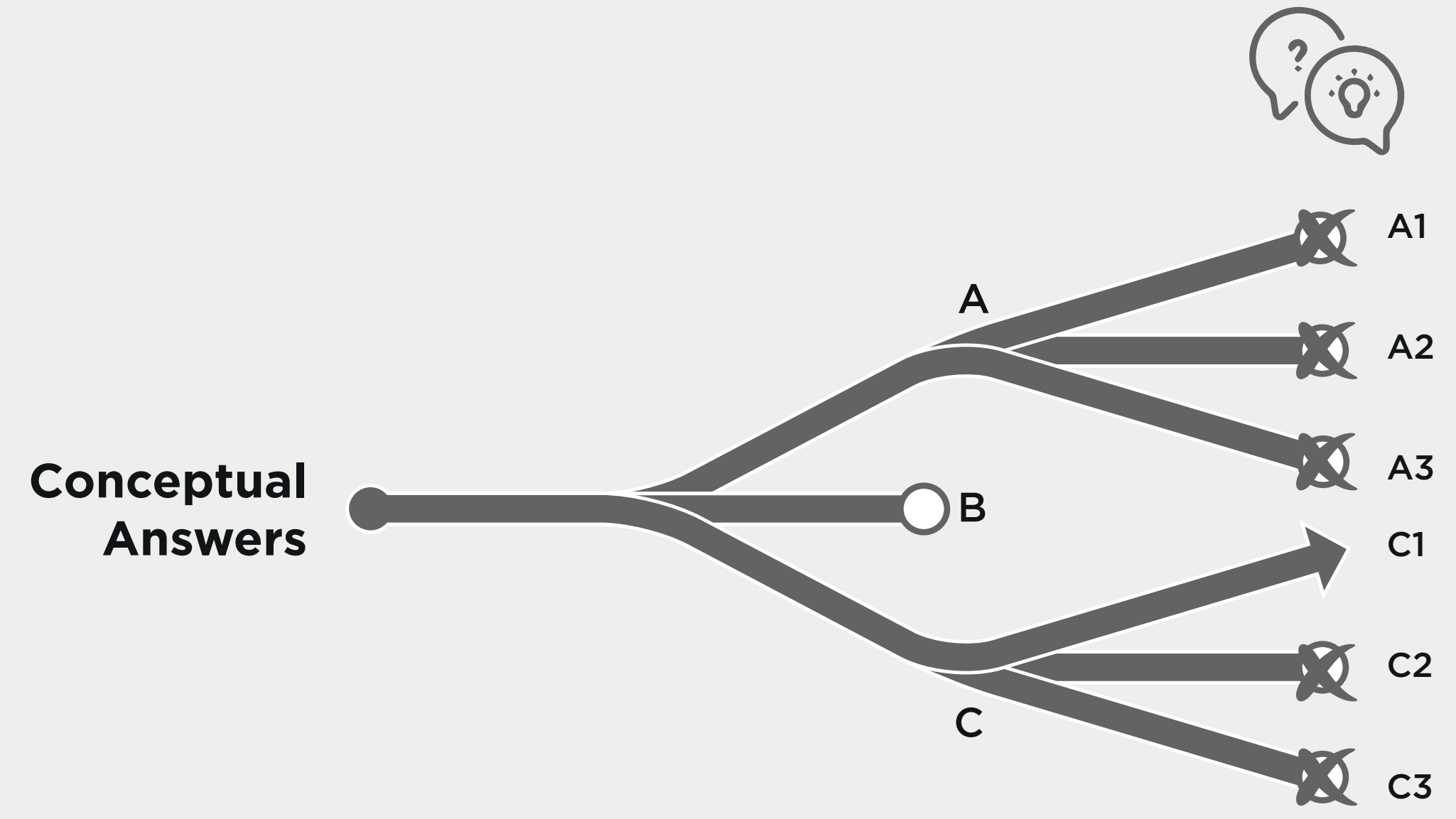

---

# Design process

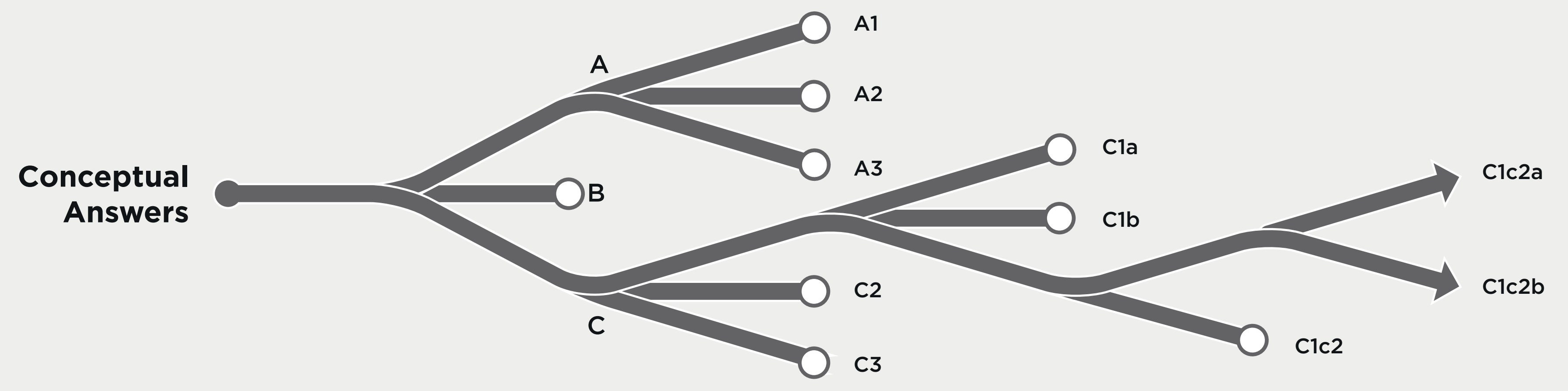

---

# Design process

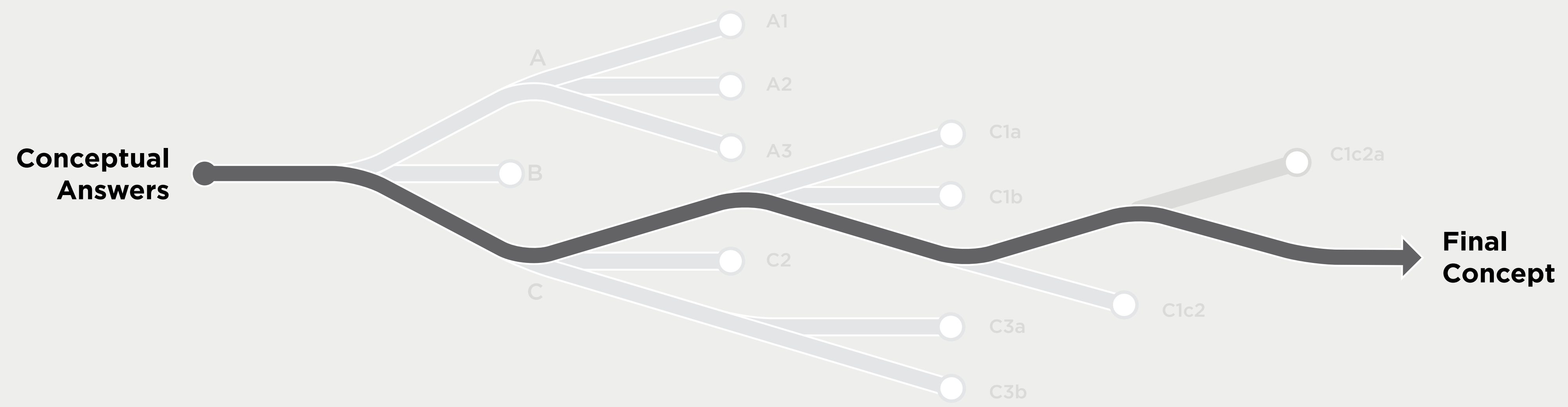

# Design process

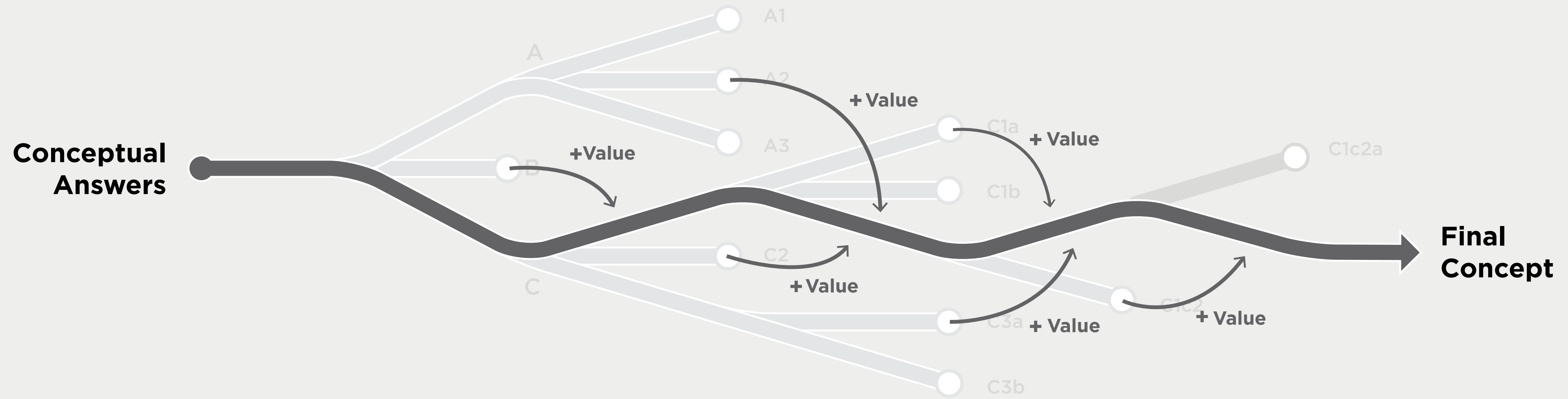



# LIVING PLACES

Proof of concept. Healthy homes with an ultra low emissions

**EFFEKT**



**Benchmark House**

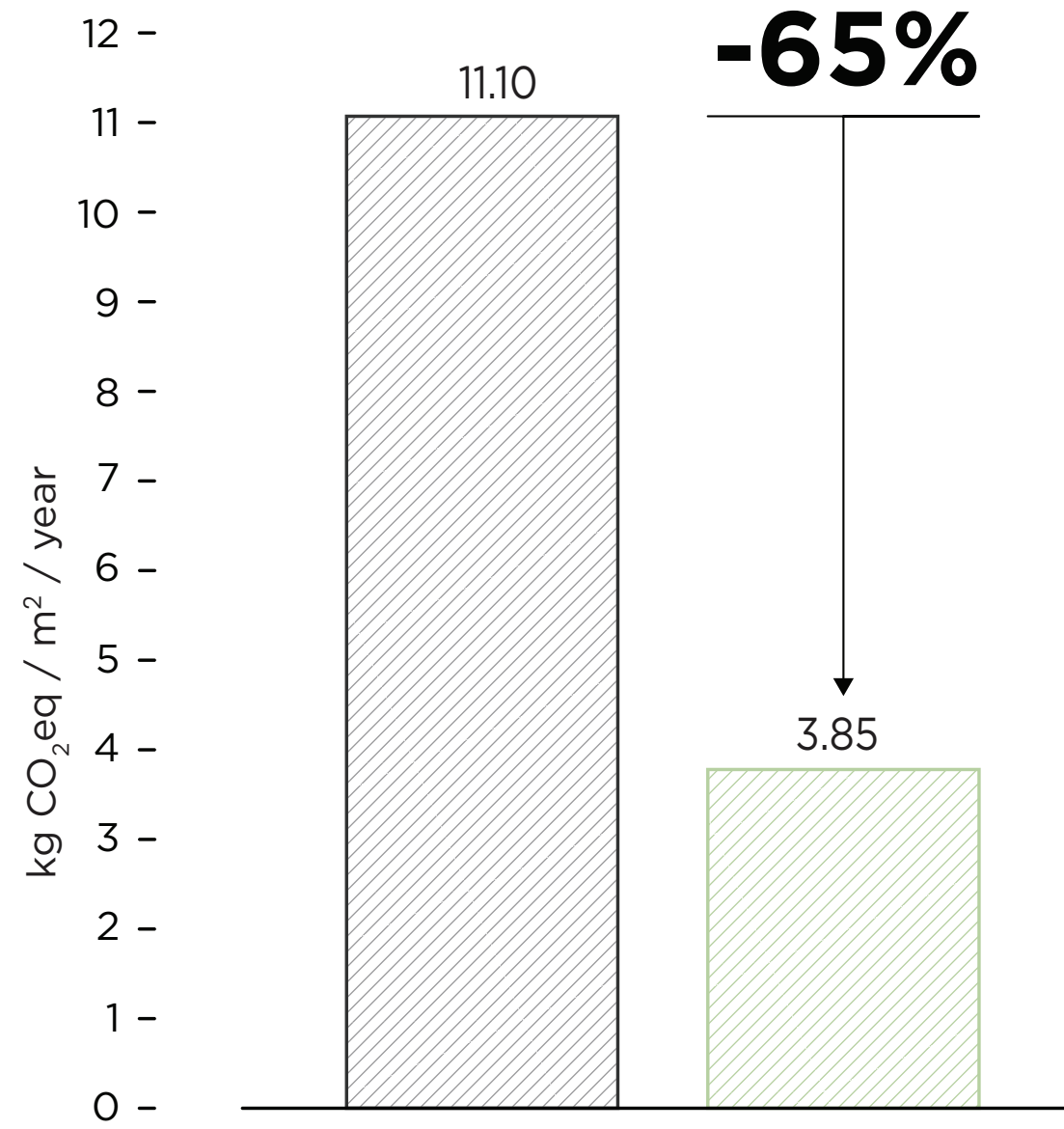

**Emission Comparison**



**Living Places**

### **Total comparison**

Comparison between the benchmark house and Living Places full LCA analysis.



**Benchmark House**

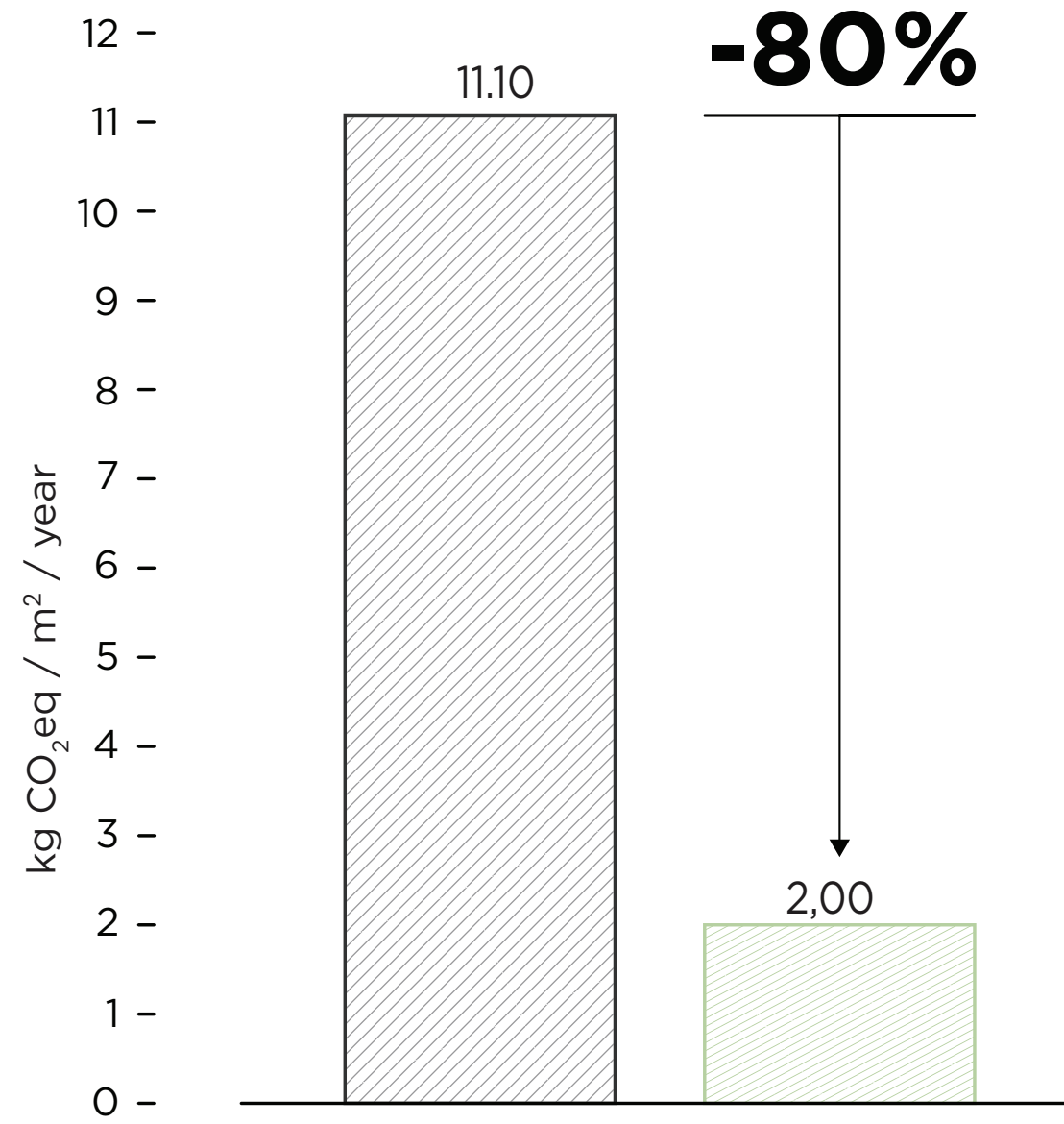

**Emission Comparison**



**Living Places 2.0**

### **Further optimization**

Comparison between the benchmark house and Living Places 2.0 full LCA analysis.

## Homes that people can afford and the planet can sustain

Home.Earth is a Danish real estate company dedicated to creating homes that respect the planet while remaining accessible and affordable to as many people as possible. The company offers an alternative, modern, and responsible approach to housing, enabling residents to reduce their carbon footprint while becoming part of a meaningful and connected community.

As a landlord, Home.Earth strives to build relationships founded on trust and shared values, prioritizing the well-being of its residents. With a strong ambition to enhance quality of life, the company ensures that all its developments achieve a thoughtful balance between people and the planet.





**Baseline**

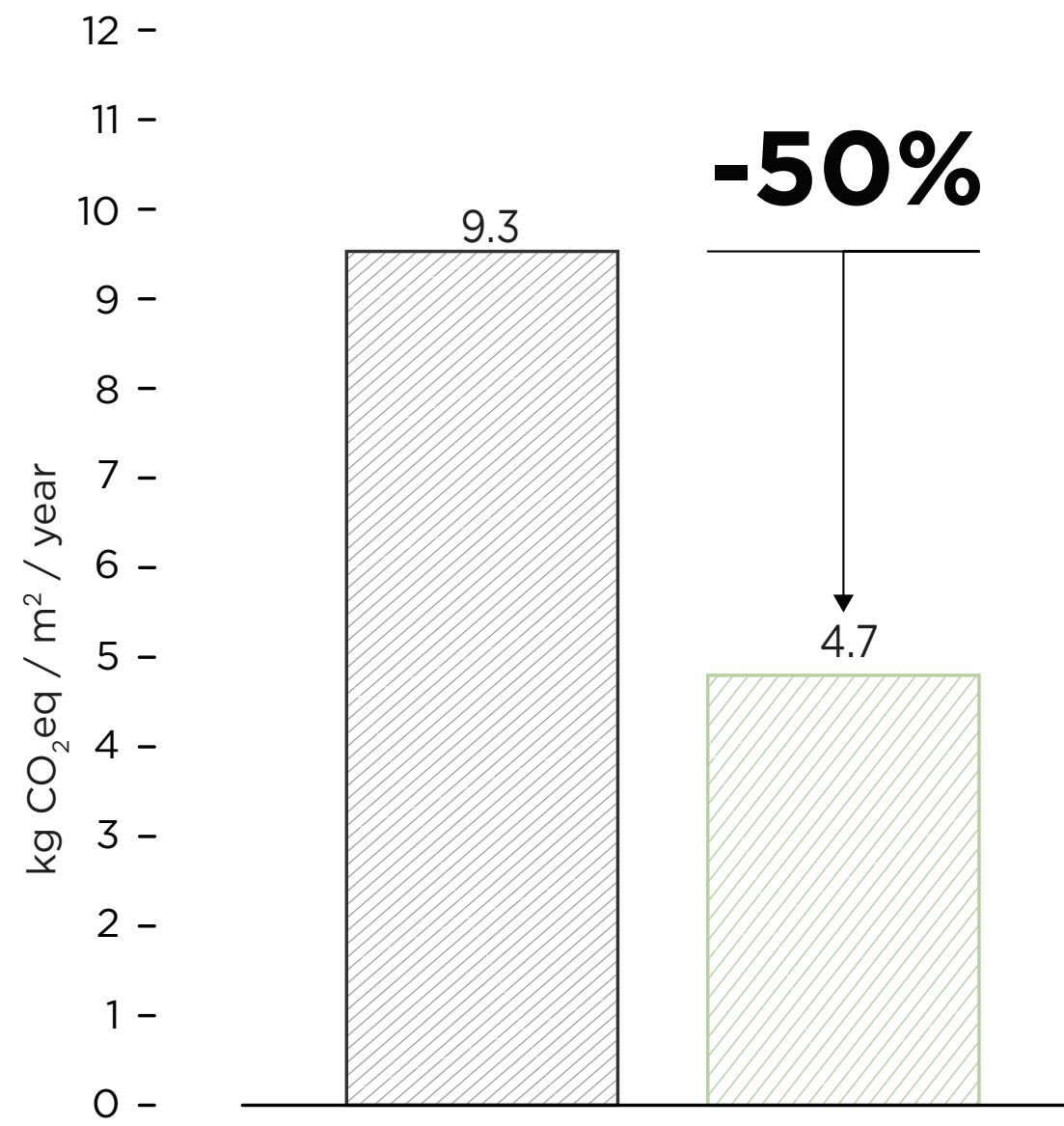

**Emission Comparison**



**Home.Earth**

### **Comparison**

Comparison between the average of a concrete multi-stores housing block and executed project of Home.Earth



**Baseline**

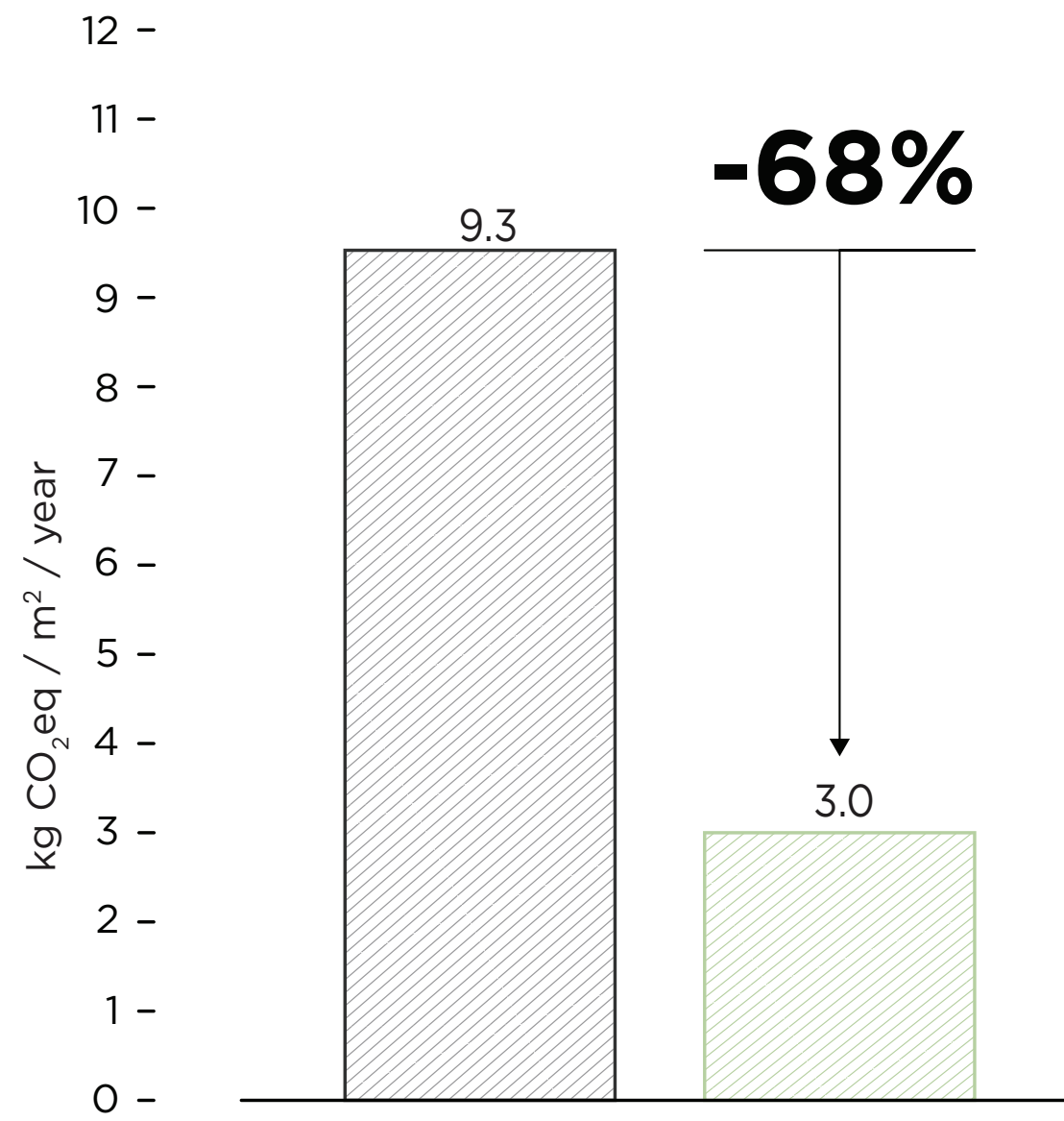

**Emission Comparison**



**Home.Earth optimized**

### **Further optimization**

Comparison between the average and Home.Earth optimized



Innovation Award 2023



Sustainable future Award



Winner 2024



Best residential project 2024



Shaping a Circular Industrial Ecosystem 2025





### **International awards**

The innovation and architectural quality has been awarded nationally in Denmark and internationally



### **20+ International press release, a book, documentaries and SM outreach**

The project has been shared internationally, reaching The times cover, featured in multiple documentaries, have a peer reviewed scientific paper about the method and a book



### **+160.000 visitors per year**

Open since 2023 has been a reference meeting point in the city of Copenhagen, with constant events and visitors.

### **50 million DKK in media value for Velux**

This proves our method delivers both environmental and commercial returns.



# Guimarões

Proof of concept. Healthy homes with an ultra low emissions

**EFFEKT**

NET  
ZERO  
CITIES



## Guimarães

“From Cradle of a Nation to Cradle of Innovation”.

Guimarães is one of the cities participating in the EU Mission to deliver **100 climate-neutral and smart cities**, and the **Pilot Cities Programme** – a component of the Mission that focuses on exploring and testing pathways to rapid decarbonisation over a two-year period.

holis-  
tisk

Guimarães





# European Green Capital 2026

As the **European Green Capital 2026**, Guimarães exemplifies how sustainability can be deeply embedded into the fabric of a community. With its residents, national partnerships, and European collaborations, the city is forging a greener, brighter future for all.

Designated a **UNESCO World Heritage** Site in 2001 for its well-preserved historic centre, Guimarães has since earned several prestigious titles: **European Capital of Culture in 2012**, European City of Sport in 2013 and the most sustainable municipality in Portugal for three consecutive years.

The municipal ecological footprint initiative serves as a guiding framework, steering Guimarães toward becoming a 'One-Planet' city.





### Brand and Commercial value

Turning sustainability into a driver of profitability and market differentiation.



### Flagship projects and market leadership

This high-visibility initiative secures international recognition and strengthen reputation



### Reporting and compliance

Provide ESG-ready data and clear reporting alignet with EU requirements.  
This strengthens investor confidence and unlocks access to favorable funding streams under the EU taxonomy.











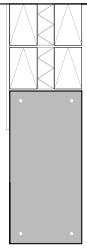
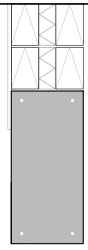
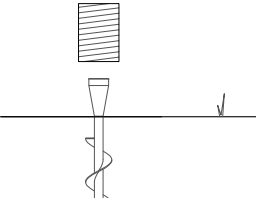
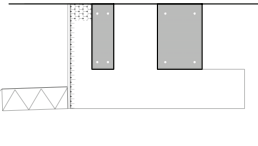

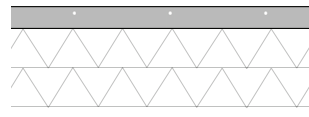
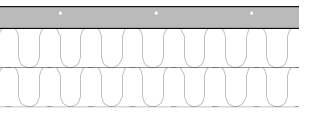
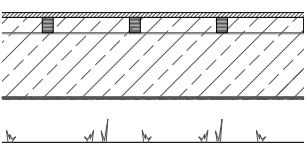
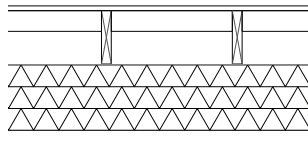
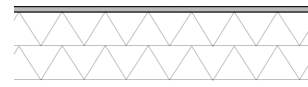
## A complete solution

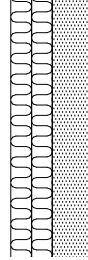
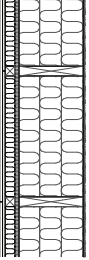
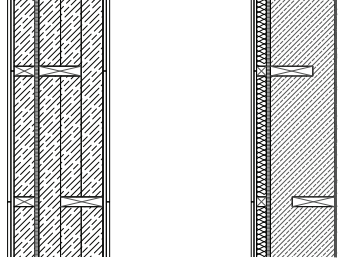
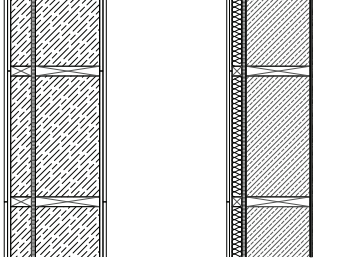
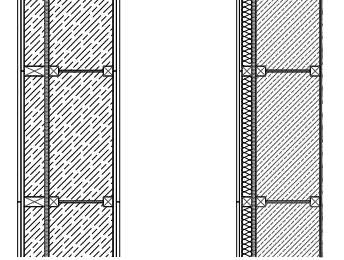
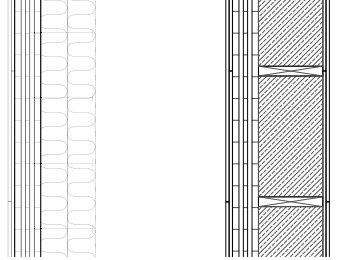
Our partnership will deliver a complete solution, that will integrate our knowledge with your infrastructure

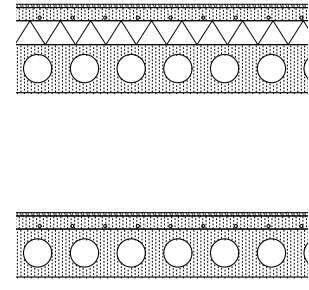
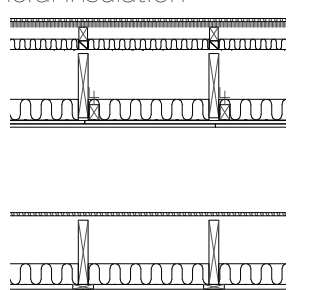
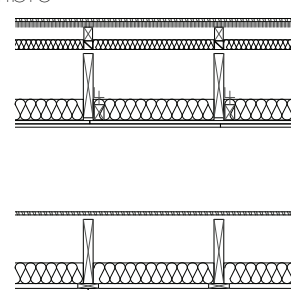
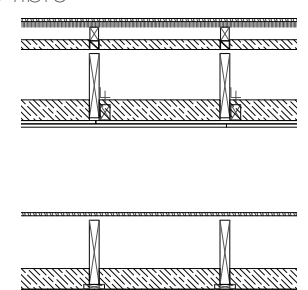
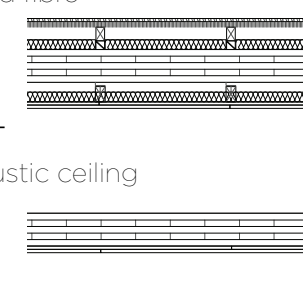
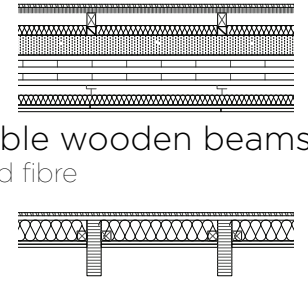
# 02. En metode til lavemissionsbyggeri

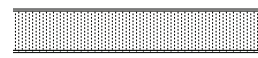
Case

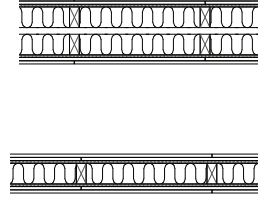
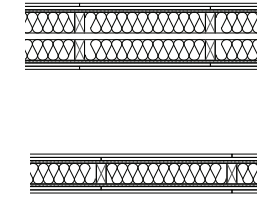
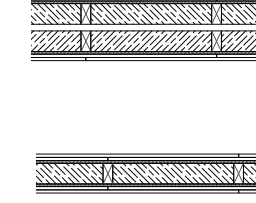
- Living Places
- Home Earth
- Guimarães

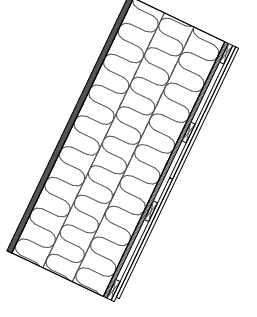
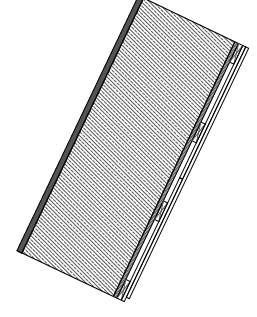
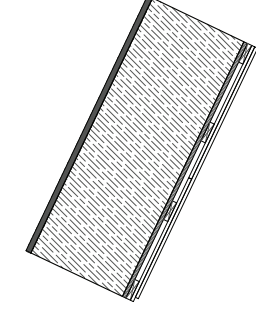
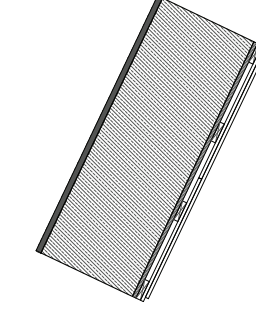
|  |   |   |  |  |  |  |
|--|---|---|--|--|--|--|
| <br><b>Foundation</b>                         | Perimeter foundation<br>Blocks and concrete<br>  | Foundations<br>Blocks and low-emissions concrete<br> | Screw piles<br>   | F-element<br>polystyrene<br>                    |  |  |
| <br><b>Terrain deck</b>                       | Concrete deck<br>polystyrene<br>  | Concrete deck<br>mineral insulation<br>              | Light elevated wooden deck<br>with cellulose insulation<br> | Light wooden deck<br>polystyrene<br>            | Light deck<br>polystyrene<br>                 |  |
| <br><b>Outer wall</b>                         | Concrete<br>mineral insulation<br>  | Timber frame<br>mineral insulation<br>               | Timber frame optimized<br>hemp // cellulose<br>             | Timber frame optimized<br>hemp // cellulose<br> | Timber frame I-beams<br>hemp // cellulose<br> | CLT<br>mineral insulation // cellulose<br>                |
| <br><b>Floor decks</b>                        | Concrete<br>   | Hidden wooden beams<br>with mineral insulation<br>  | Hidden wooden beams<br>wood fibre<br>                      | Hidden wooden beams<br>hemp fibre<br>          | CLT<br>wood fibre<br>                        | CLT + Concrete<br>Visible wooden beams<br>wood fibre<br> |
| <br><b>Interior wall<br/>Partition wall</b> | Concrete<br><br>Metal frame<br>mineral insulation<br> | Timber frame<br>mineral insulation<br>             | Timber frame<br>wood fibre<br>                            | Timber frame<br>hemp fibre<br>                | CLT<br>with gypsum<br>                      |  |
| <br><b>Roof</b>                             | Timber frame<br>mineral insulation<br>  | Timber frame<br>cellulose<br>                      | Timber frame<br>hemp<br>                                  | Timber frame I-beams<br>cellulose<br>         |  |  |

### Multi-store housing analysis

Fire and Acoustic requirements have been included in the studies for multi storage houses, row houses and blocks.

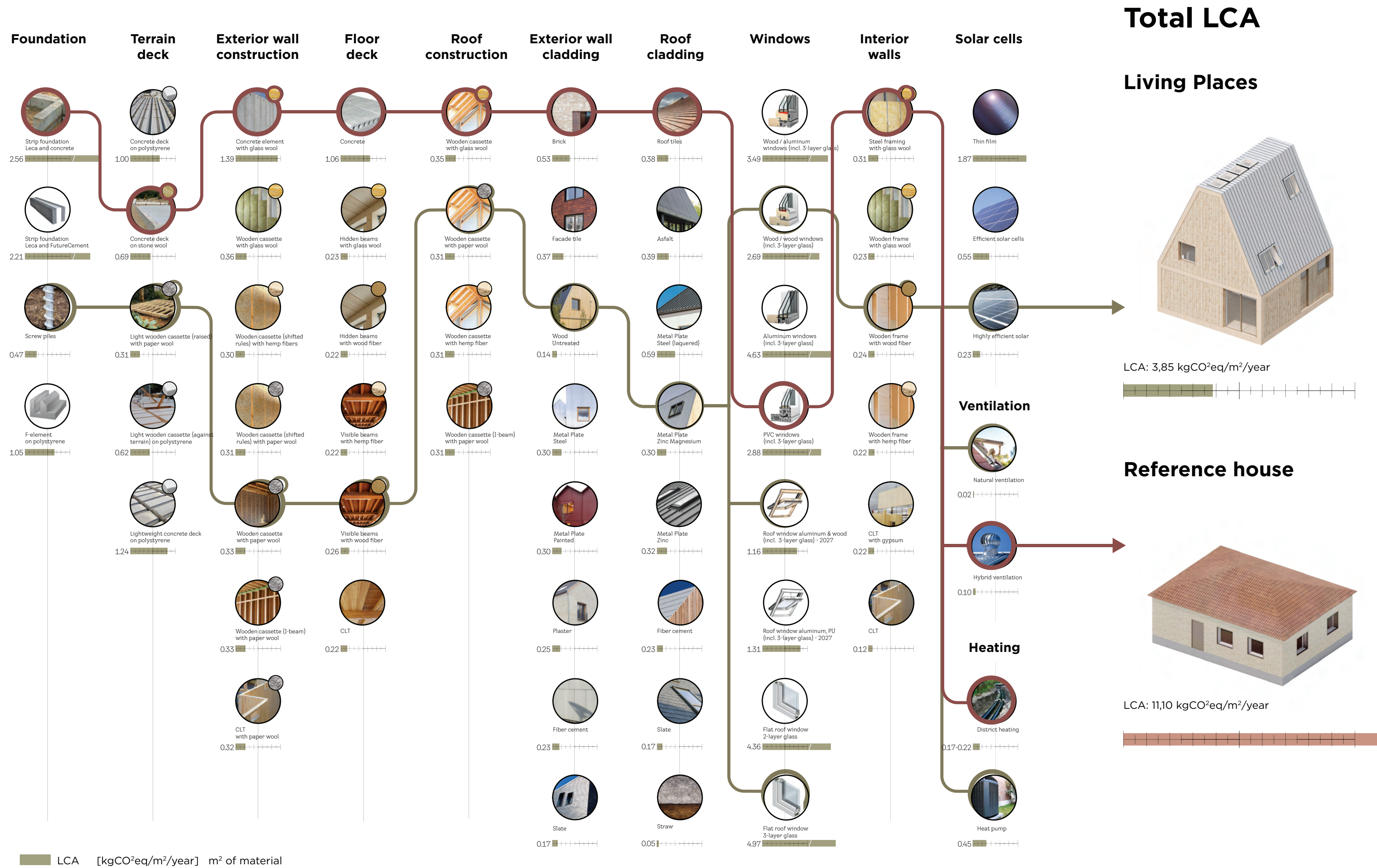

# LIVING PLACES

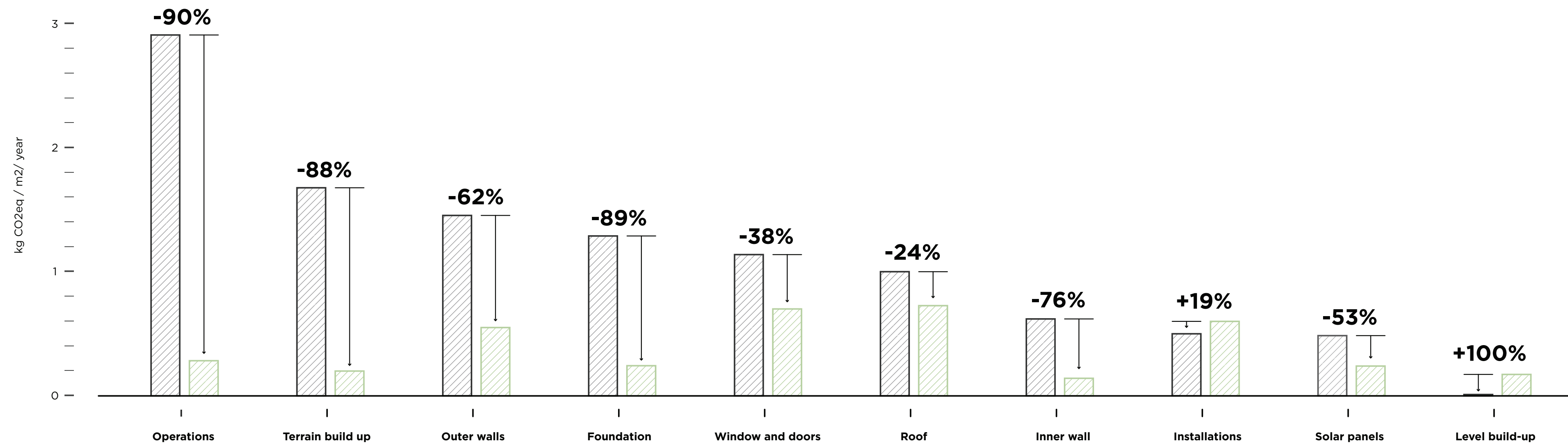

**Optimization on each component**

### Concrete element

with glass wool

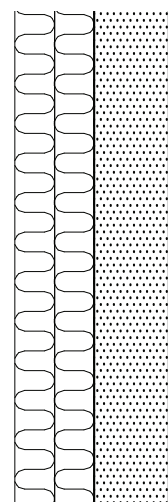

### Timber frame

with glass wool

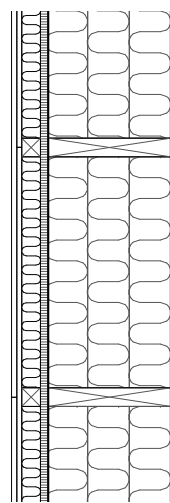

### Timber frame (sifted)

with paper insulation

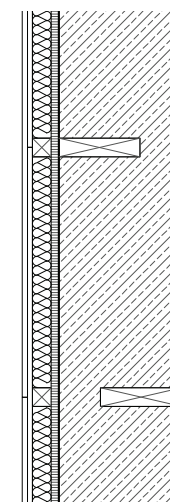

### Timber frame (I-beams)

with paper insulation

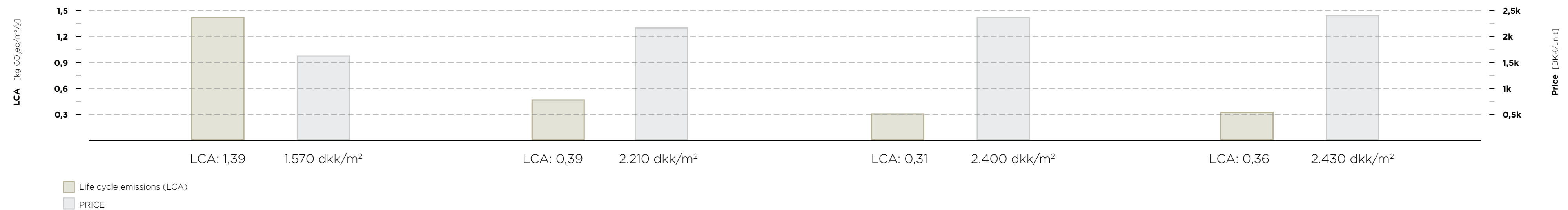
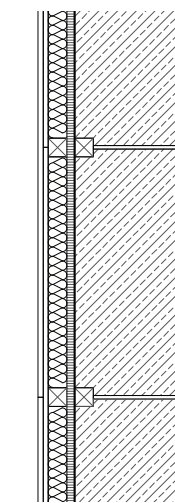

## Scalability: LCA and Cost

By using the process, we have investigated various build ups. We have developed LCA, prices and detailed drawing for numerous versions. This catalogue can be expanded and serves as a knowledge bank for the team.

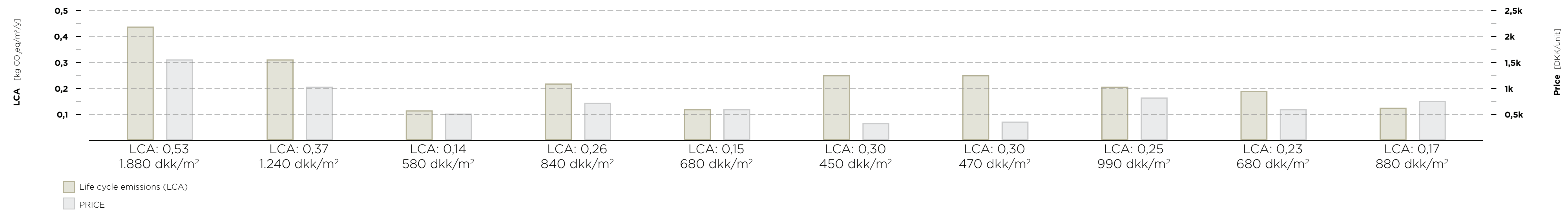
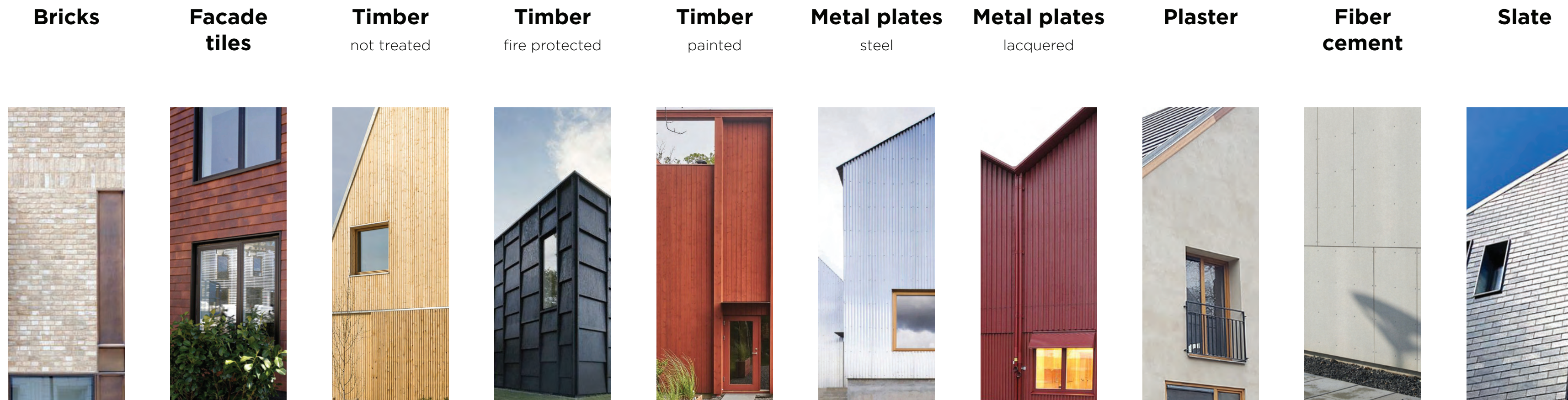

### Scalability: LCA and Cost

Following the same methodology we research individual materials, for interior and exterior finishes, adjusting to project and client's specific needs and requirements.

## Facade elements

### Type 1

Fermacell power panel HD  
Timber frame 250 mm (timber ration 23%)  
Isover Ultimate  
OSB

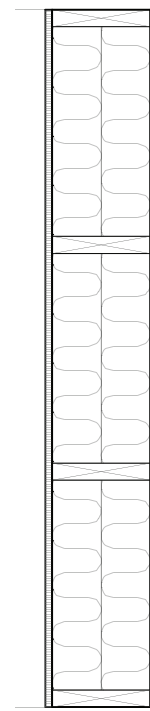

### Type 2

Cembrit windstoper basic  
Timber frame 250 mm (timber ration 18 %)  
Isover  
OSB

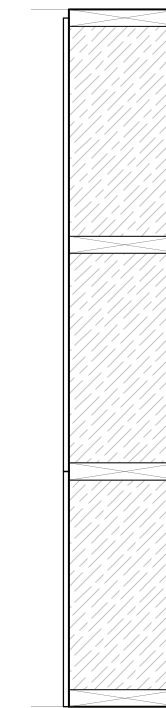

### Type 3

Cembrit windstoper basic  
Timber frame 160 mm (timber ration 18 %)  
Isover  
OSB

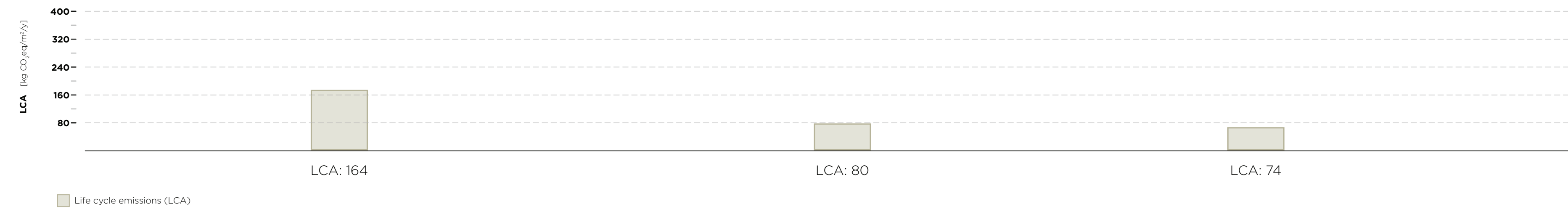
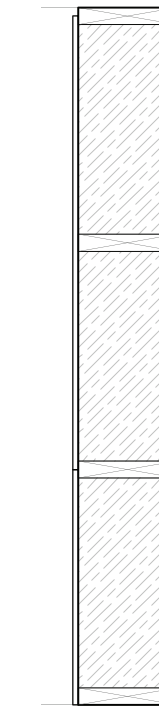

### Optimization process

Each component (Exterior wall, Interior wall, deck...) can be optimized by selecting the right materials and layer composition

## Facade elements

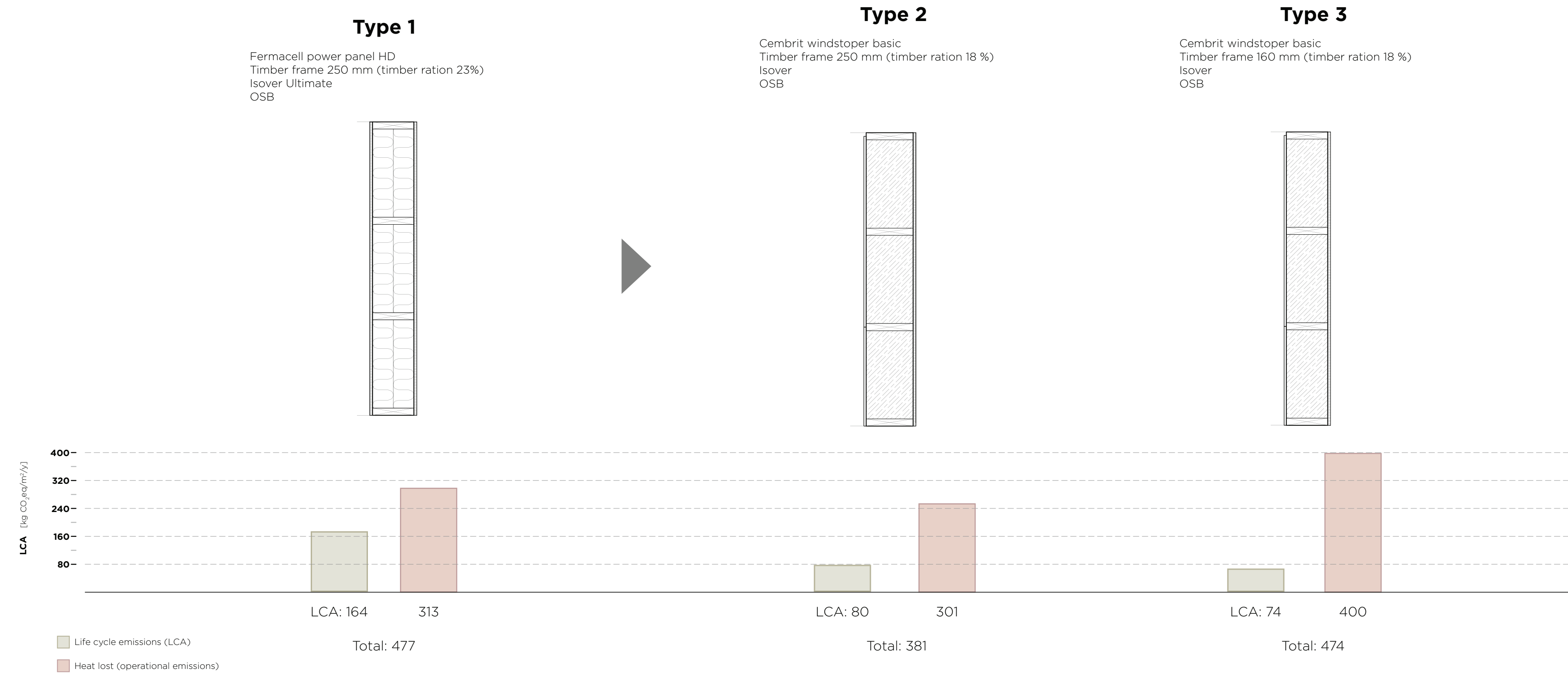

### Optimization process

The thickness and properties of the insulation affects the heat loss, if accounting for it, a better picture of the performance of each solution is showcase

## Facade elements

7 year estimated payoff period for the increase in insulation

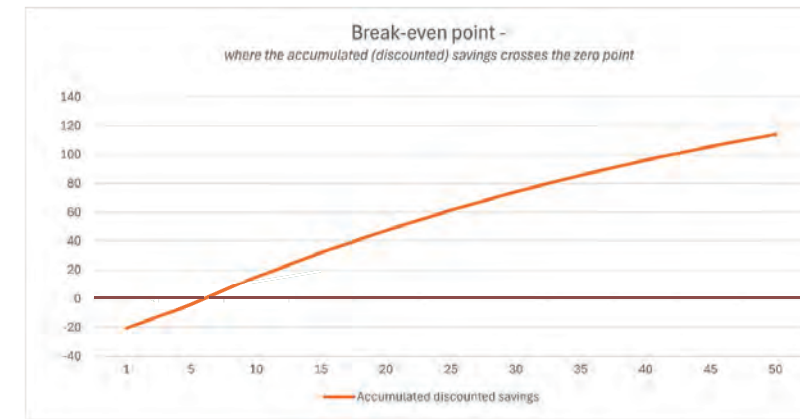

### Type 1

Fermacell power panel HD  
 Timber frame 250 mm (timber ration 23%)  
 Isover Ultimate  
 OSB

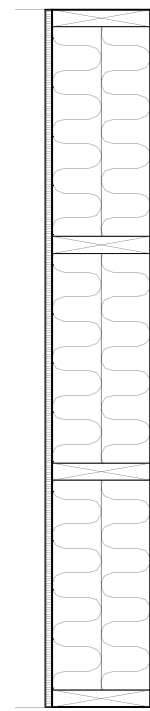

### Type 2

Cembrit windstoper basic  
 Timber frame 250 mm (timber ration 18 %)  
 Isover  
 OSB

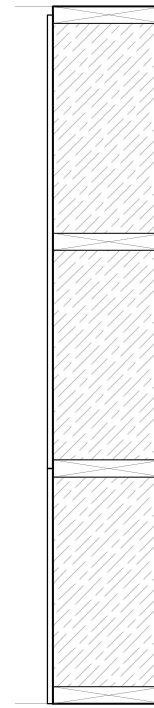

### Type 3

Cembrit windstoper basic  
 Timber frame 160 mm (timber ration 18 %)  
 Isover  
 OSB

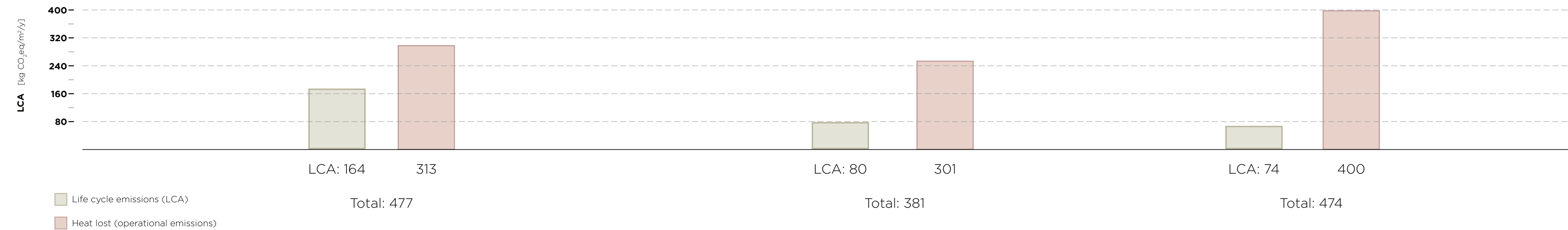
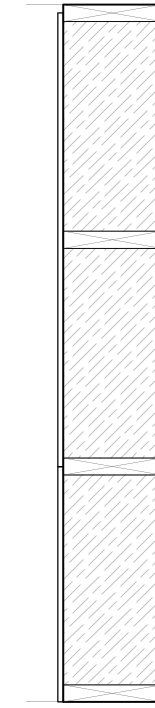

## Economic assessment

An additional 5% investment in extra insulation will not only provide a climate benefit but will also pay for itself in 7 years through accumulated operational savings

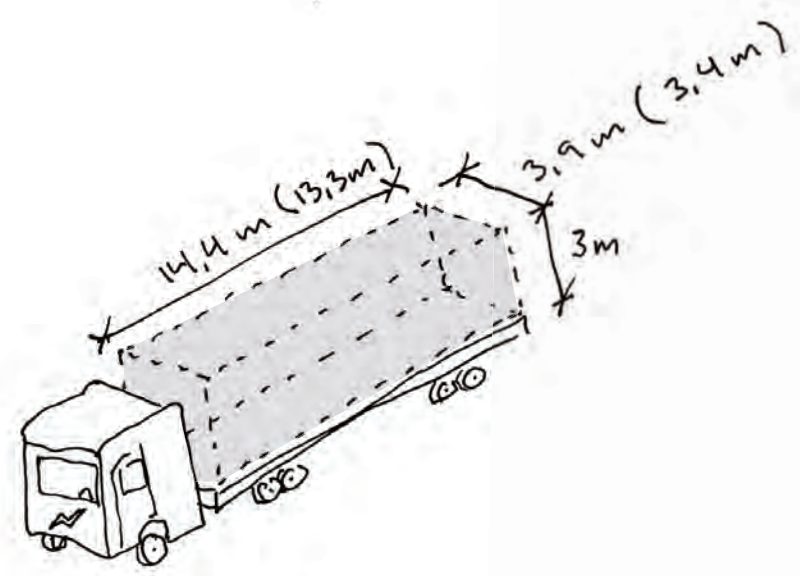

**Transport limitations**

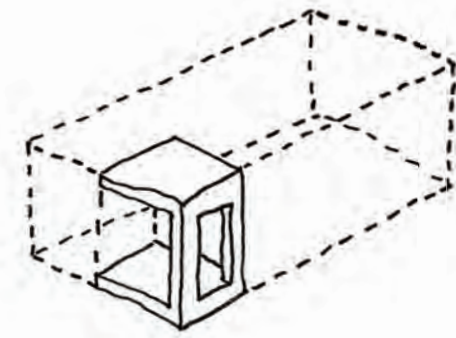

**DNA**

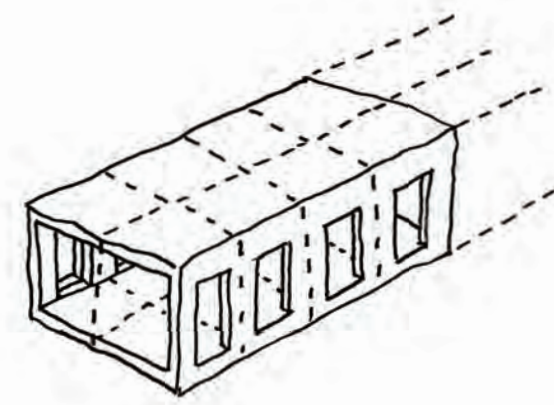

**Module**

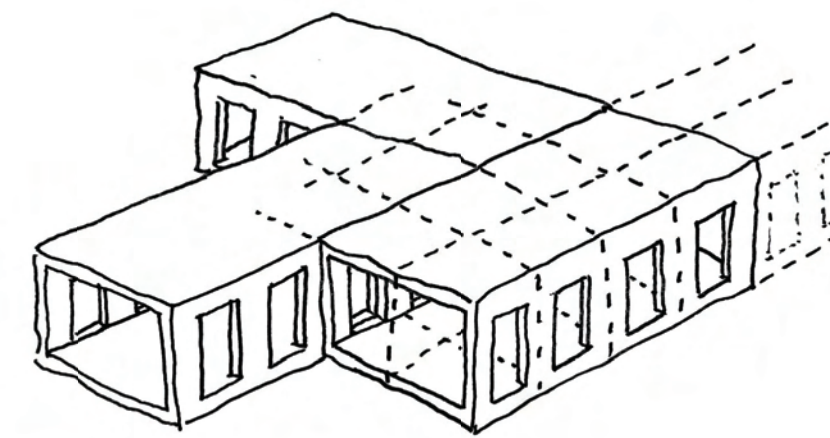

**Combinations**

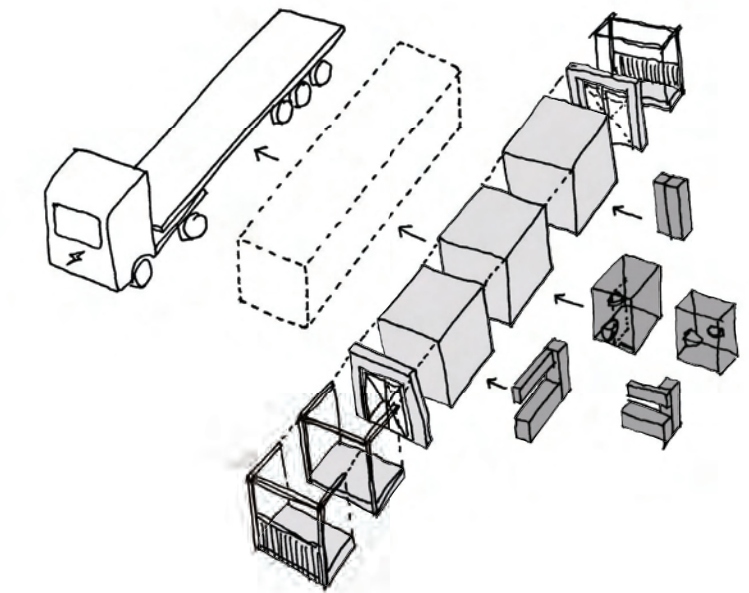

**Components**

## **Modularity**

Based on transport dimensions, a basic unit is created that works as a Lego system, creating modules that can combine in endless options, and fill with also modular components

## Building



Living Places

Simple home  
Smart appliances

## Components

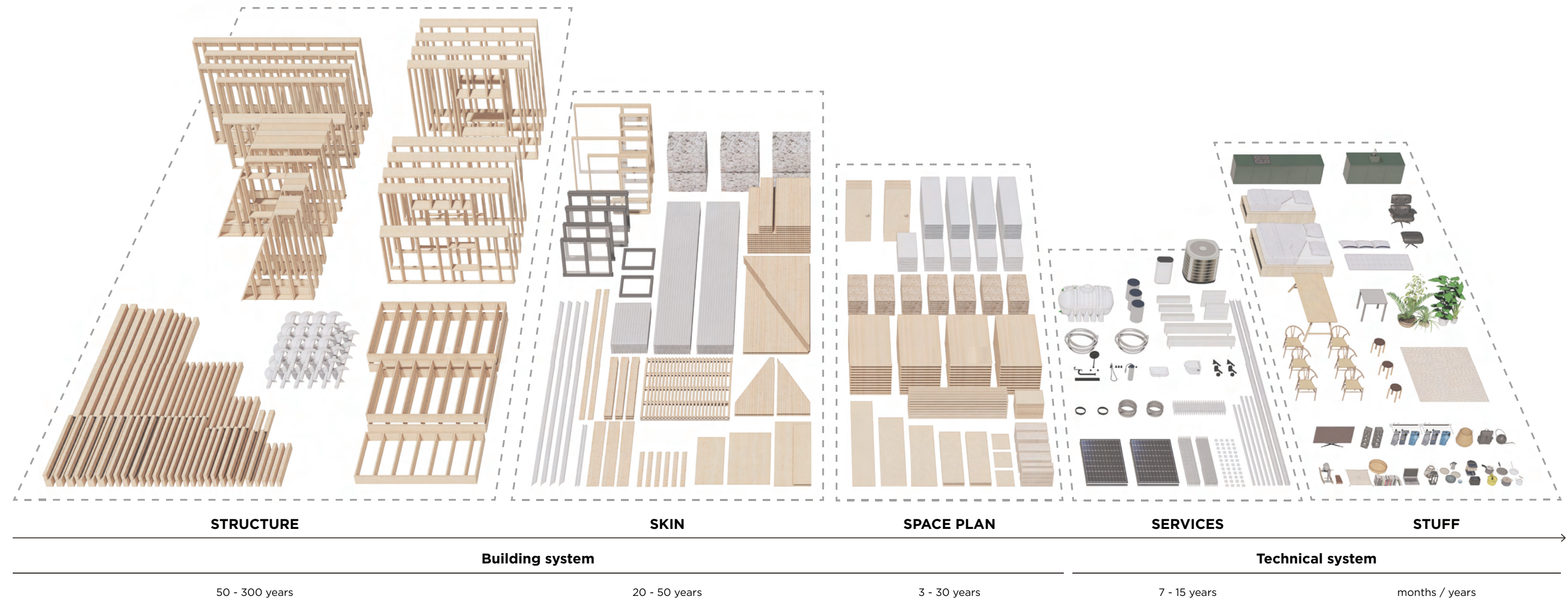

### Design for disassembly - Lifespan of building parts

The design-for-disassembly method, by facilitating easy repairs, upgrades, and recycling, extends product lifetimes and curbs waste. This approach, which emphasizes re-usability and resource efficiency for sustainability, also ensures that the easiest components to replace have the shortest lifetimes, aligning maintenance with product longevity.



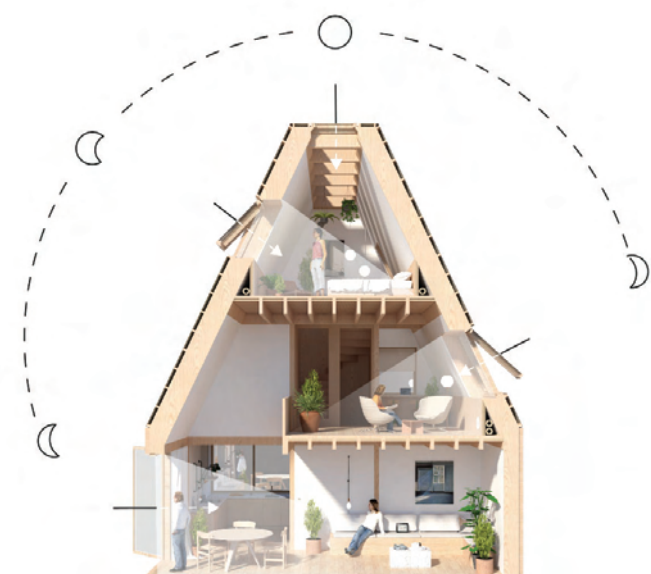

Daylight principles



Thermal environment principles

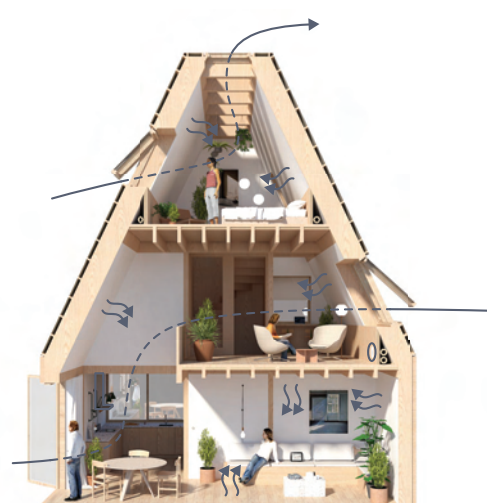
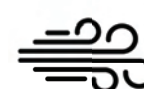

Indoor air quality principles

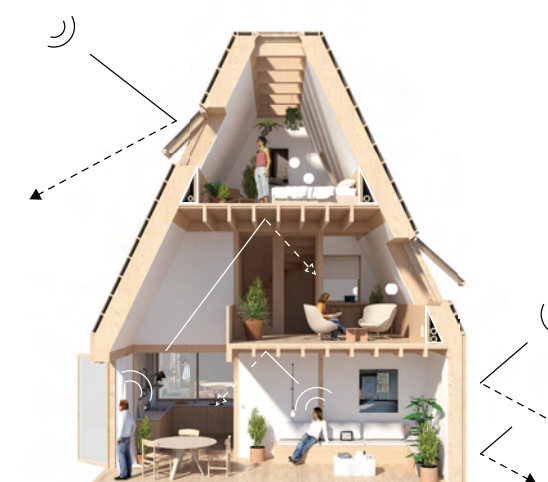

Acoustics principles



Outdoor connection principles

### Healthy building principle

To ensure a first class indoor environment we have based the methodology for Living Places on the healthy building principles. These are split into 5 categories - daylight, Thermal environment, indoor air quality, acoustics and outdoor

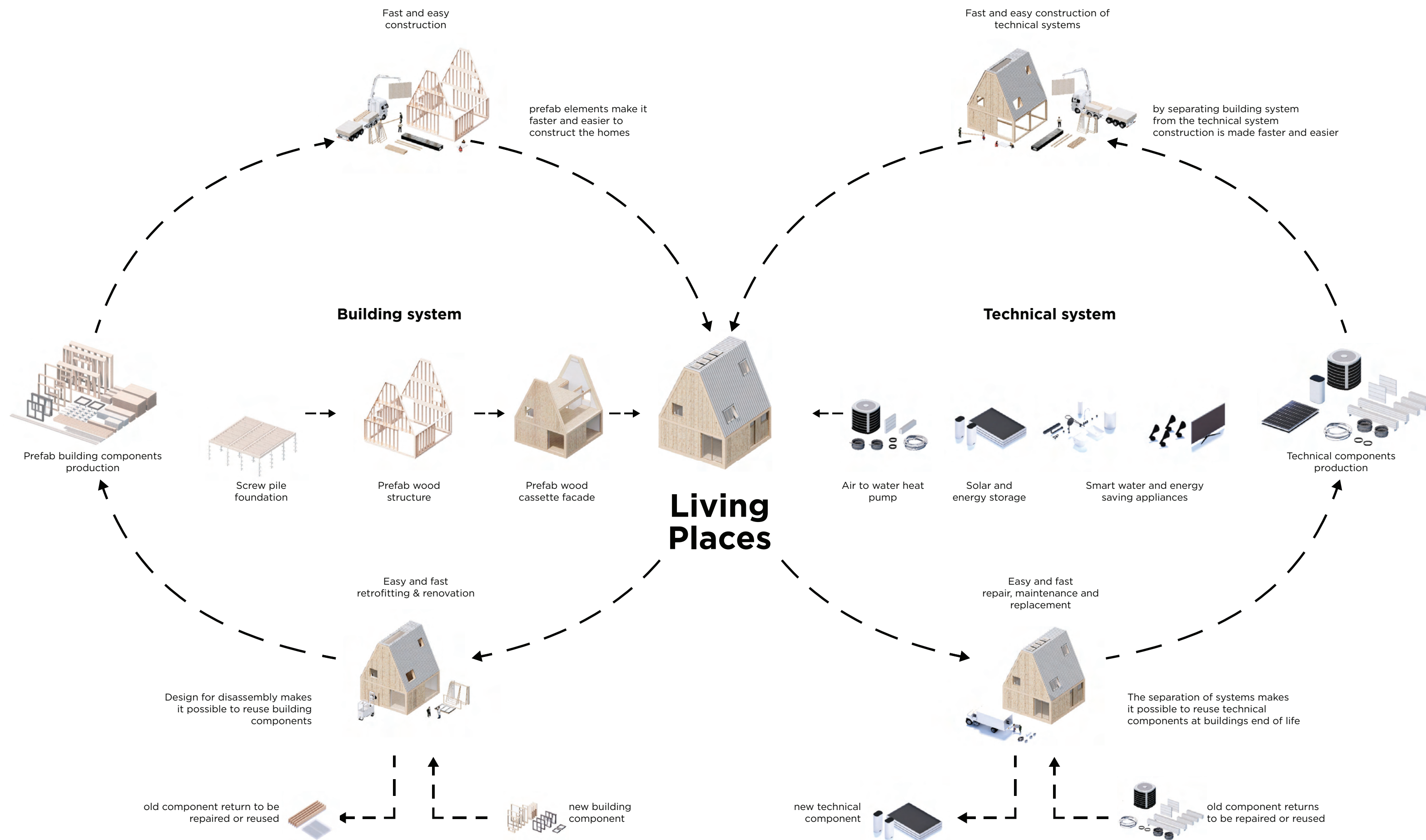

### Simple building system and Technical system

By separating the building systems from the technical system and designing the homes so that these are easy to access and maintain, repair, and replace we create homes that can accommodate new technical systems efficiently and at a reduced cost.

# Living Places Copenhagen Results

Living Places Concept has Denmark's lowest CO<sub>2</sub> footprint and a first-class indoor climate. It has been built using existing technologies and materials, demonstrating that we do not have to wait for future technology to build far more sustainable homes that are healthy, affordable and beautiful to live in.

Starting from the ground up - each building component has been optimized for the best constellation of price, indoor climate and carbon footprint, with a special focus given to the envelope of the building where significant CO<sub>2</sub> savings can be achieved.

As a result, Living Places Concept has received third-party verification from AAU BUILD to have almost 3x lower CO<sub>2</sub> footprint than an average Danish single-family house at 3.85 kg CO<sub>2</sub> eq per m<sup>2</sup>/year compared to 11.10 kg CO<sub>2</sub> eq per m<sup>2</sup>/year for an average new build, Danish single-family house.

Furthermore, Living Places is designed with a strong focus on creating a healthy indoor climate using daylight and fresh air and has been awarded a best-in-class indoor climate.

## Environmental impact

3x lower LCA

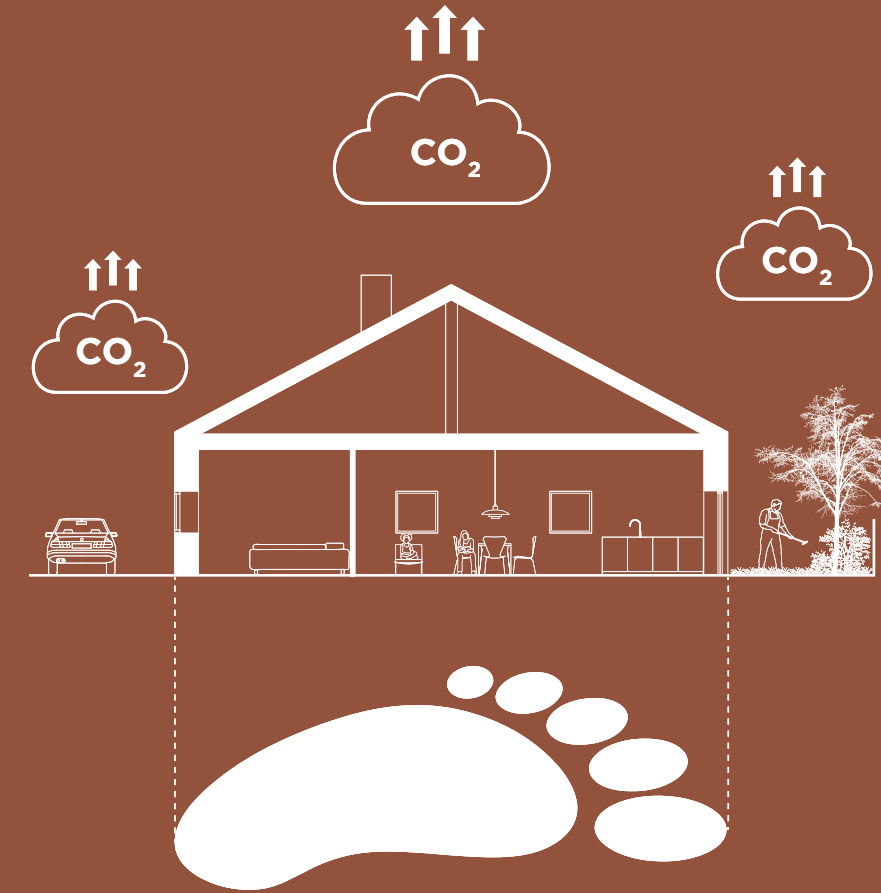

11.10 kg CO<sub>2</sub>/m<sup>2</sup>/year



3,85 kg CO<sub>2</sub>/m<sup>2</sup>/year

## Health impact

3x better indoor climate class

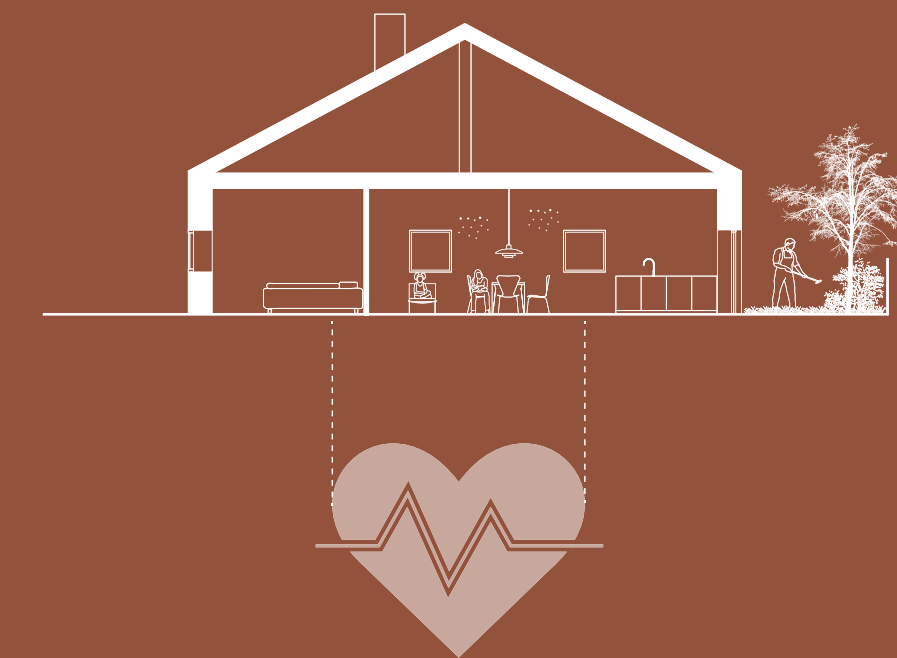

Indoor climate class 3



Indoor climate class 1

# 03. Heuristikker

---

# Heuristikker

Teamet Før Teknikken

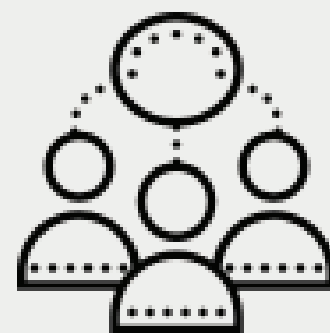

Vind Kampen, Før den Starter

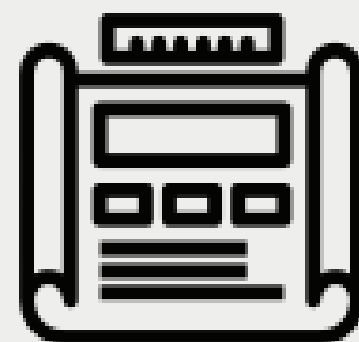

Byg på Viden, Ikke på Gæt

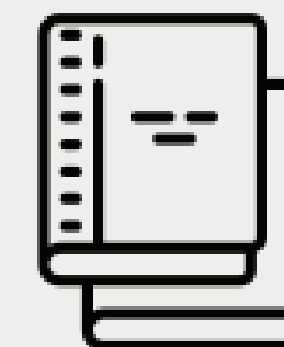

# Teamet Før Teknikken

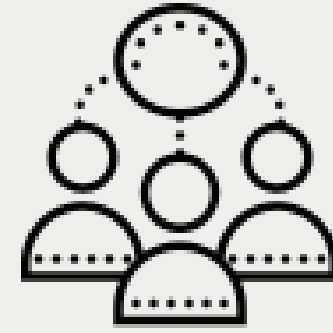

# Teamet Før Teknikken

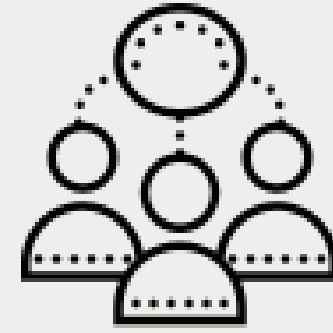

Vælg jeres partner, ikke jeres udbudsform

# Teamet Før Teknikken

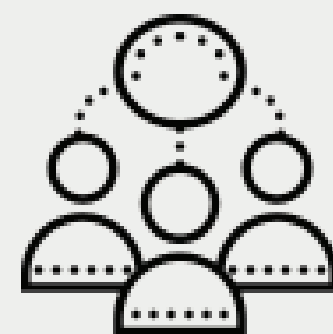

Vælg jeres partner, ikke jeres udbudsform



Design kontrakter til samarbejde, ikke til konflikt

# Teamet Før Teknikken

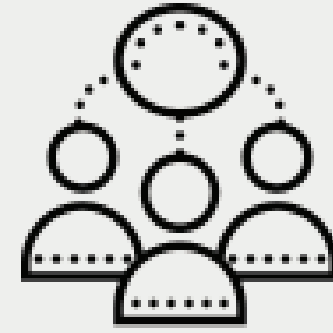

Vælg jeres partner, ikke jeres udbudsform



Design kontrakter til samarbejde, ikke til konflikt



Én sandhed, ét bord

# Teamet Før Teknikken

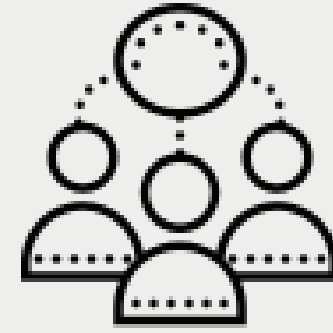

Vælg jeres partner, ikke jeres udbudsform



Design kontrakter til samarbejde, ikke til konflikt



Én sandhed, ét bord

# Vind Kampen, Før den Starter

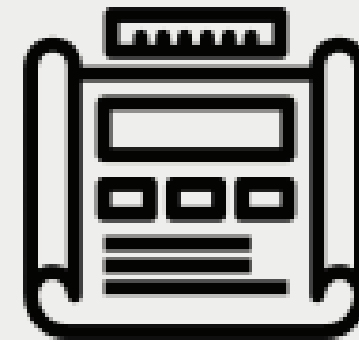

# Vind Kampen, Før den Starter

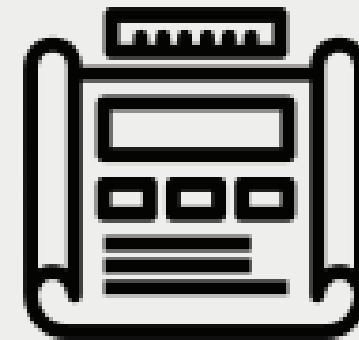

Definér succes og arbejd baglæns

# Vind Kampen, Før den Starter

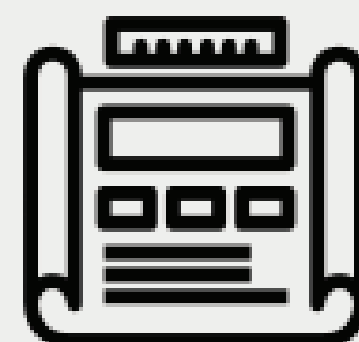

Definér succes og arbejd baglæns



Gennemarbejd detaljen, hvor fejl er billigst

# Vind Kampen, Før den Starter

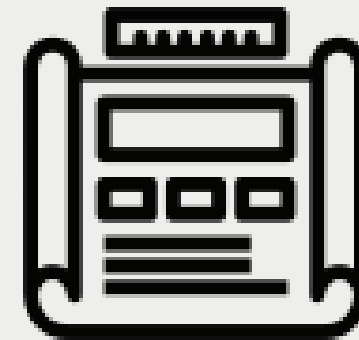

Definér succes og arbejd baglæns



Gennemarbejd detaljen, hvor fejl er billigst



Lås køreplanen, før I starter

**Byg på Viden, Ikke på Gæt**

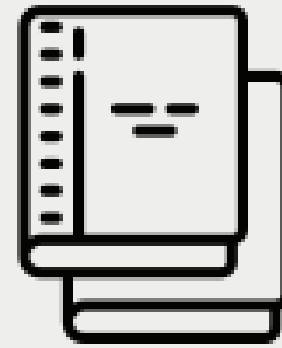

# Byg på Viden, Ikke på Gæt

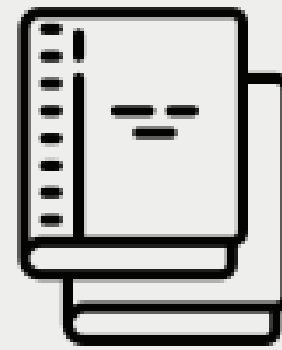

Opsøg erfaring

# Byg på Viden, Ikke på Gæt

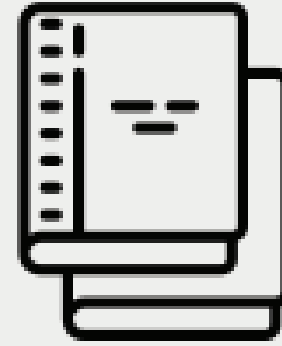

Opsøg erfaring



Test i fuld skala, før I bygger

# Byg på Viden, Ikke på Gæt

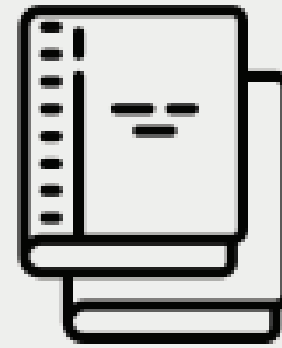

Opsøg erfaring



Test i fuld skala, før I bygger



Brug data, ikke plejer

# Tak

**EFFEKT Architects**

Follow us

[www.effekt.dk](http://www.effekt.dk)

[www.biomehousing.com](http://www.biomehousing.com)

LinkedIn : [linkedin.com/company/effekt](https://www.linkedin.com/company/effekt)

Instagram : [@effektarchitects](https://www.instagram.com/effektarchitects)

Visit us

Blågårdsgade 8, 2200 København Tel. +45 35 35 36 31 E-mail: [hello@effekt.dk](mailto:hello@effekt.dk)